

	I	GB	D	F	E
ICW ISO228/1-G2	INGRESSO ACQUA REFRIGERATA	CHILLER WATER INLET	KALTWASSEREINGANG	ENTREE EAU GLACEE	ENTRADA AGUA ENFRIADA
UCW ISO228/1-G2	USCITA ACQUA REFRIGERATA	CHILLER WATER OUTLET	KALTWASSERRAUSGANG	SORTIE EAU GLACEE	SALIDA AGUA ENFRIADA
IHW	INGRESSO ACQUA CALDA	HOT WATER INLET	WARMWASSEREINGANG	ENTREE EAU CHAUDE	ENTRADA AGUA CALIENTE
UHW	USCITA ACQUA CALDA	HOT WATER OUTLET	WARMWASSERRAUSGANG	SORTIE EAU CHAUDE	SALIDA AGUA CALIENTE
IP	INGRESSO CAVO DI ALIMENTAZIONE	POWER SUPPLY CABLE INLET	SPEISEKABELINGANG	ENTREE CABLAGE D'ALIMENTATION	ENTREE CABLAGE ALIMENTATION
IS	INGRESSO USCITA SEGNALI	SIGNALS INLET / OUTLET	EINGANG / AUSGANG SIGNALE	ENTREE / SORTIE SIGNALES	ENTRADA / SALIDA SINIALIZACIONES
IR	INGRESSO RETE	NETWORK INLET	NETWERKEINGANG	ENTREE RESEAU	ENTRADA RED
F Ø 6	INGRESSO ACQUA UMIDIFICATORE	HUMIDIFIER WATER INLET	WASSEREINGANG BEFEUCHTER	ENTREE EAU HUMIDIFICATEUR	ENTRADA AGUA HUMECTADOR
C-D Ø 32	SCARICO ACQUA UMIDIFICATORE E/O CONDENZA	HUMIDIFER / CONDENSATE DRAIN CONNECTION	KONDENSAT - BZB. BEFEUCHTERAB - FLUSS	DECHARGE EAU HUMIDIFICATEUR ET/OU CONDENSEUR	DESCARGA AGUA HUMECTADOR Y/O CONDENSADOR
AR Ø 100	INGRESSO ARIA DI RINNOVO	FRESH AIR INLET	FRISHLUFTEINGANG	ENTREE AIR NEUF	ENTRADA AIRE DE RENOVO
I W1-2 ISO228/G1*1/2A	INGRESSO ACQUA CONDENSAZIONE	CONDENSING WATER INLET	WASSERGEKUEHLTER VERFLISSINGER-EIN	ENTREE EAU DE CONDESATION	SALIDA AGUA DE CONDENSACION
U W1-2 ISO228/G1*1/2A	USCITA ACQUA CONDENSAZIONE	CONDENSING WATER OUTLET	WASSERGEKUEHLTER VERFLISSINGER-AUS	SORTIE EAU DE CONDENSATION	SALIDA AGUA DE CONDENSACION
Modelli Model	TDE-W-D 2242	TDE-W-D 2542	TDE-W-D 2842	TDW 3342	
Peso Weight (Kg)	996	1020	1120	1140	

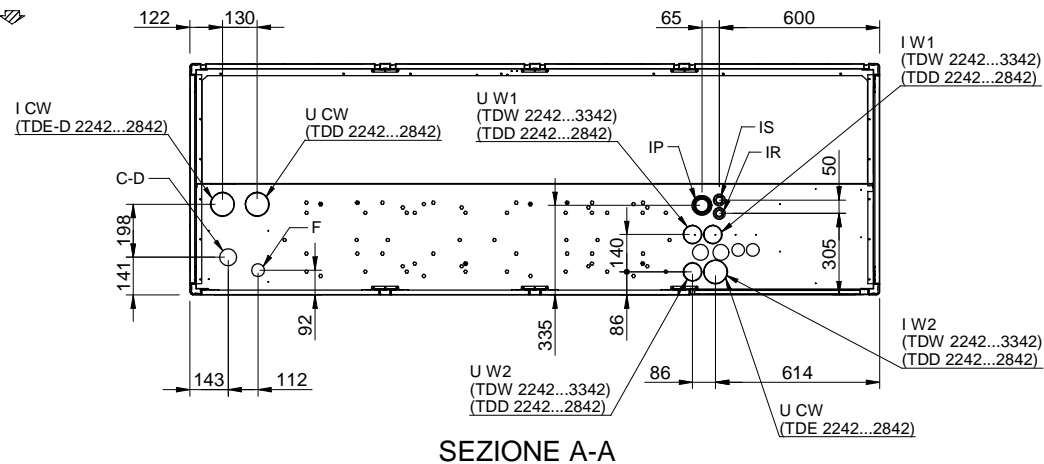
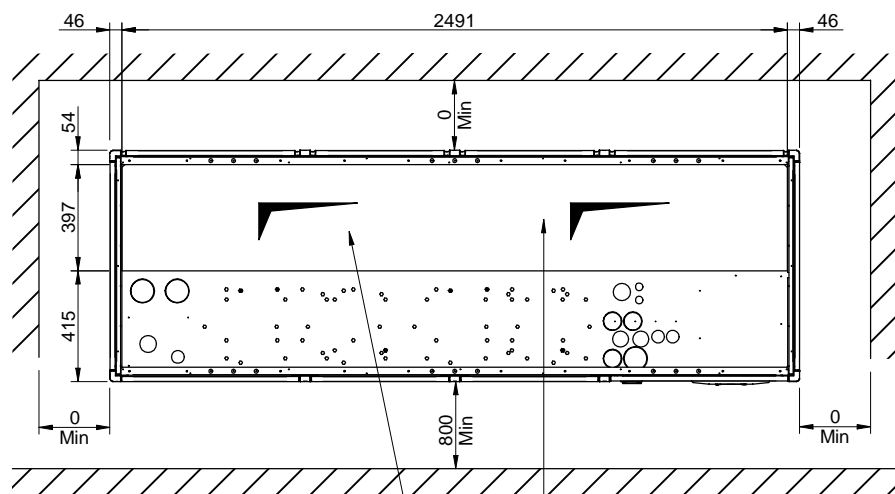

USCITA ARIA REFRIGERATA  
TREADED AIR DISCHARGE  
ZULUFTAUSGANG  
SORTIE AIR GLACEE  
SALIDA AIRE ENFRIDA

A	Modificato Ingresso Cavi e Resistenze	M.Chiodetto	25/06/07		
REV.	Descrizione - Description	Disegnatore - Draftsman	Data - Date	Visto - Checked by	n' Com.
	Materiale - Material	Trattamento - Treatment			Rif. Com.
		Denominazione-Denomination <b>DISEGNO DI INSTALLAZIONE</b> <b>INSTALLATION DRAWING</b>		Series <b>TDE-W-D</b> Modello-Model <b>2242...3342</b>	
Scala-Scale	QUOTE SENZA INDICAZIONE DI TOLLERANZA	Dis.-Draftsman V.Tramontan	Foglio Sheet N. 1/1	Disegno-Drawing DIC1912X2A	REV. A
	Grado di precisione medio UNI EN 22768-1(1996)	Visto-Checked by	Data-Date 04/04/2007		